

CARSONITE PRODUCT SPECIFICATION FOR ROADMARKER (CRM-375)

1 SCOPE

This specification covers the requirements for materials of construction, performance, installation, and maintenance for Carsonite glass reinforced composite markers. These markers may be used to provide daytime and nighttime delineation for roadways or other marking applications requiring assured long-term durability, lightweight, flexibility, and vehicle impact resistance.

2 GENERAL REQUIREMENTS

2.1 DESIGN

The CRM-375 Marker shall be a single piece marker capable of simple, permanent installation by one person using a manual driving tool. The CRM-375 upon proper installation shall resist displacement from wind and vehicle impact forces. The CRM-375 shall be of a constant flat "T" cross sectional design to accept retroreflective sheeting with reinforcing support ribs incorporated longitudinally along each edge to provide sheeting protection and structural rigidity. The bottom end of the marker shall be pointed for ease of ground penetration.

2.2 MATERIAL

2.2.1 Marker:

The CRM-375 Marker shall be constructed of a durable, UV resistant, continuous glass fiber and marble reinforced, thermosetting composite material which is resistant to impact, ozone, and hydrocarbons within a service temperature range of -40°F to +140°F.

2.2.2 Sheeting:

The customer shall specify sheeting.

2.3 WORKMANSHIP

The CRM-375 Marker shall exhibit good workmanship and shall be free of burns, discoloration, cracks, bulges or other objectionable marks which would adversely affect the marker's performance or serviceability.

2.4 MARKING

Each CRM-375 shall be permanently identified with the manufacturer's name and the month and year of fabrication. The letters shall be a minimum of 3/8-inch in height, and permanently affixed to the rear of the marker. A black line shall be stamped horizontally across the front of the marker near the bottom to indicate proper burial depth.

3 PHYSICAL AND MECHANICAL REQUIREMENTS

3.1 DIMENSIONS

The CRM-375 flexible marker shall conform to the shape and overall dimensions shown in Figure 1.

3.1.1 Width

The nominal CRM-375 Marker width shall be 3.75 inches in order to accommodate a three-inch wide reflector and provide adequate daytime delineation.

3.1.2 Length

The CRM-375 shall be of such length to provide the required height above the road surface with a minimum embedment depth of 18 inches.

3.2 MECHANICAL PROPERTIES

The CRM-375 shall have the minimum mechanical properties as follows:

<u>PROPERTY</u>	<u>ASTM TEST METHOD</u>	<u>MINIMUM VALUE</u>
Ultimate Tensile Strength	D-638	50,000 psi
Ultimate Compressive Strength	D-638	45,000 psi
Specific Gravity	D-792	1.7
Weight % Glass Reinforcement	D-2584	50%
Barcol Hardness	D-2583	47

3.3 COLOR FASTNESS

The CRM-375 shall be pigmented throughout the entire cross-section so as to produce a uniform color, which is an integral part of the material. Ultraviolet resistant materials shall be incorporated in the construction to inhibit fading or cracking of the delineator upon field exposure.

3.4 COLD FLEXIBILITY

A four foot marker shall be conditioned for a minimum of two hours at $-40^{\circ}\text{F} \pm 3^{\circ}\text{F}$. The unit shall then be held at the bottom end in a vertical position and the top end bent 90° such that it parallels the floor. The marker shall return to within 5° of the upright position within 30 seconds. The bend test shall be repeated three times in quick succession, completing the test within 2.5 minutes of post removal from the conditioning temperature.

3.5 COLD IMPACT RESISTANCE

The CRM-375 shall be conditioned a minimum of two hours at $-40^{\circ}\text{F} \pm 3^{\circ}\text{F}$. A minimum two-pound spherical weight shall be dropped a distance of five feet through a virtually frictionless vertical guide to impact the surface of the marker at mid section. The surface of the post being struck by the steel ball shall be in a horizontal position with the post supported and held in position at both ends. The post shall be subjected to five impact tests concentrated near the middle of the post within 10 minutes from the removal from the environmental chamber. Fracturing, cracking, or splitting of the posts shall constitute failure.

Another conditioned marker shall be struck flush against a flat solid surface three times within two minutes after removal from the conditioning chamber. To strike the marker it should be manually swung through a 90° arc, and the marker shall not fracture or shatter upon impact.

3.6 VEHICLE IMPACT RESISTANCE

The Carsonite CRM-375 Marker shall be capable of self-erecting and remain functional after being subjected to a series of ten head on impacts by a typical passenger sedan at 55 m.p.h. The CRM-375 shall retain a minimum of 60% of its sheeting.

4 INSTALLATION REQUIREMENTS

4.1 INSTRUCTIONS

The proper installation instructions shall be provided in a pamphlet format with each marker shipment.

5 MARKER REMOVAL REQUIREMENTS

The CRM-375 Marker shall be typically removed with a Carsonite CPP Post Remover.

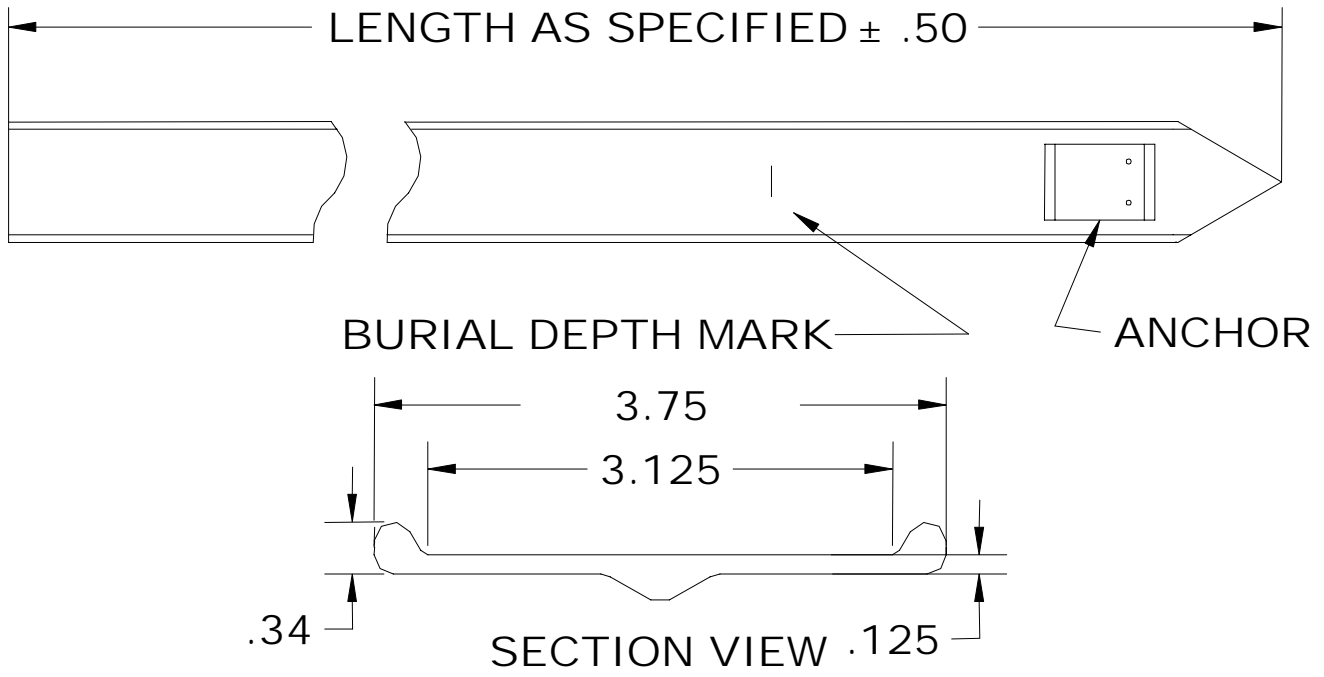

FIGURE 1